

# Couples Range

Tough enough for the outback. Perfect for two.



**SLEEPS UP TO 3**  
QUEEN OR KING BED



**KITCHEN**  
INTERNAL & EXTERNAL COOKING



**FRIDGE**  
INDOOR FRIDGE



**LAUNDRY**  
LAUNDRY CHUTE & WASHING MACHINE



**FULL ENSUITE**  
SHOWER/ TOILET



**BATTERIES**  
OFF-GRID BATTERIES



**SOLAR**  
MASSIVE SOLAR CAPABILITY WITH OPTIONAL SLIDE-OUT SOLAR PANELS

Australian made & owned.



# our X-range

## Kokoda: Generator-Less by Design

Other vans are still stuck in the past — framed vans with poor insulation, big vents that leak dust, messy wiring that wastes solar, and power-hungry aircons that force you to run a generator. They're really generator vans, no matter what they bolt onto it.

**Kokoda's X-Ranges are different.** We design the whole system as one — body, insulation, energy, heating, cooling, and storage — so everything works in harmony. The result? A van that feels effortless, no matter how harsh the conditions.



### Better Insulation

Our bonded sandwich panels, and fully insulated hatch doors keep the cabin warm in winter and cool in summer. In the XG range, the cabin is fully gas-free — no gas ventilation cut-outs, no insulation gaps, no dust creeping in. Just quiet, steady comfort.

### Smarter Energy Flow

Shorter, direct cabling means less loss from solar to batteries. What you collect, you keep — making every ray of sunlight count. Airflow and heat extraction around the battery management components, to ensure they run efficiently in the hottest climates.

### Efficient Climate Control

We choose air conditioners that sip power, not gulp it. In the XG range, the ducted split system

uses just 700W an hour — so you can run it longer, sleep cooler, and wake warmer without draining your bank.

### Balanced Energy Sources

Where others rely on just electric or diesel, Kokoda uses all three: Gas for hot water + outdoor cooking (outside the cabin, keeping it gas-free).

Diesel for reliable heating.

Electric (solar + lithium + inverter) for everything inside: aircon, appliances, lighting, comfort.

### The Outcome

With Kokoda, what most people see as endurance — blistering heat, biting cold, or days without sun — becomes simple, quiet, and comfortable. You spend more time off-grid, with less management and far less generator noise.











**That's why we call ours generator-less caravans.**

**Everyone else? They're still making generator vans.**

**pushing boundaries, on and off the road.**

# X-range specs



		XC		XG	
		XC1	XC2	XG1	XG2
energy	 <b>gas</b>	2× 4.5kg gas bottles	2× 4.5kg gas bottles	2× 4.5kg gas bottles	2× 4.5kg gas bottles
	 <b>diesel</b>	5 Litres	5 Litres	5 Litres	5 Litres
	 <b>solar</b>	860w	1290w	1720w	2150w Option: 2580w for vans over 21'
	 <b>battery</b>	400a / 12v	600a / 12v	920a / 12v	1884a / 22kw / 12v (DCX 2× 942a batteries)
	 <b>inverter</b>	3kw inverter	3kw inverter	5kw inverter	5kw inverter
	 <b>battery management</b>	5" Cerbo Screen, Victron Mppts, 100/50 30a DC-DC Charger 120a Charger Resetable Fuses and a Spare provided for any non-resetable fuse	5" Cerbo Screen, Victron Mppt, 2× 100/50 30a DC-DC Charger 120a Charger Resetable Fuses and a Spare provided for any non-resetable fuse	5" Cerbo Screen, Victron Mppt, 3× 100/50 30a DC-DC Charger 120a Charger Resetable Fuses and a Spare provided for any non-resetable fuse	5" Cerbo Screen, Mppt 3× 100/50 (Option 4x) 30a DC-DC Charger 120a Charger Resetable Fuses and a Spare provided for any non-resetable fuse
	 <b>suspension</b>	Teko Independent Coil Spring Suspension	140mm Travel – Teko Tuffride, Auto Ride Height Levelling, Onboard aircompressor and tank with air outlets each side of the van and at the aframe.	230mm Travel – Terraglide TG-X-1, Phone & Onboard Management, Horizon Levelling, Auto Ride Height Levelling, Onboard dual aircompressor and tank with air outlets each side of the van and at the aframe.	230mm Travel – Terraglide TG-X-1, Phone & Onboard Management, Horizon Levelling, Auto Ride Height Levelling, Onboard dual aircompressor and tank with air outlets each side of the van and at the aframe.
	 <b>tool-boxes</b>	Large Dual Slide Toolbox  REAR: Standard rear bar with single spare wheel	Monster Toolbox (Incorporated stone guard and internal gas bottle storage)  REAR: Standard rear bar with single spare wheel	FRONT: XCore Front & Garage  REAR: XCore rear bar with glove box	FRONT: XCore Front & Garage  REAR: XCore rear bar with glove box
	 <b>water</b>	220 Litres of water *2× 110L tanks	220 Litres of water *2× 110L tanks	330 Litres of water *3× 110L tanks	330 Litres of water *3× 110L tanks
	 <b>grey water</b>	40 Litre Portable Tank	40 Litre Portable Tank	40 Litre Portable Tank	90 Litre Fixed

pushing boundaries, on and off the road.



Australian made & owned.



## XC range - climate control & comfort in every season

The XC Range is Kokoda's mainstream choice built for those who want to travel further, stay longer and feel comfortable in any climate. Whether it's weekends away, annual holidays or months-long journeys, this is the range that adapts to your lifestyle.

### the mission

To deliver true comfort and capability across every kind of adventure, in every season.

### the features that enable it

Composite sandwich panel construction provides superior insulation and dust control, meaning the cabin holds temperature without draining power. A balanced solar and lithium system, paired with smart airflow and heating/cooling options, keeps life on the road simple and comfortable. Styled with Kokoda's rugged design cues, the XC Range blends toughness with everyday ease.

### the experience

The XC gives you the confidence to roam widely, without worrying about conditions. From coastal holidays to inland journeys, from hot summers to cool southern nights, it adapts to you. It's freedom made comfortable, all year round.



## why choose the XC range?

Engineered to keep you comfortable through Australia's toughest conditions. The perfect balance of strength, insulation, and seasonal comfort.

**engineered for comfort in every climate.**

## XC1 range - disconnect from civilisation, reconnect with life

Built for **off-grid escapes** — weekends, annual holidays, and quick getaways where freedom, simplicity, lightness, and affordability matter most. It's about the kind of travel where setup is easy, towing feels light, and you can head out on a Friday night knowing everything you need is onboard.

The XC1 is fitted with **upgraded solar, battery, and inverter systems**, giving you enough off-grid capability to power lights, fridges, pumps, and devices and 240v appliances without ever firing up a generator. Gas cooking and diesel heating keep things simple, reliable, and efficient, so you're never stuck without a hot meal or warmth on a cool night. The bonded sandwich panel body ensures the cabin holds its temperature better, meaning less energy wasted and more comfort inside.

This van is built to make **escape feel effortless**. Head bush, tuck into a forest, or roll up by a river bend — you'll have the space, comfort, and capability to recharge, without overthinking or overspending. The XC1 is the perfect companion for families and couples who want to get away, breathe deeper, and return home refreshed.

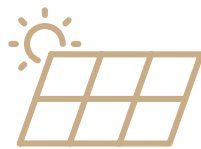

### solar

860w

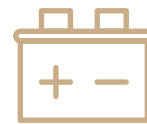

### battery

400a / 12v



### suspension

Teko Independent Coil Spring Suspension



### battery management

**Victron Battery Management**  
5" Cerbo Screen,  
Victron Mppt,100/50  
30a DC-DC Charger  
120a Charger  
Resetable Fuses and a Spare provided for any non-resetable fuse



### hitch

Cruisemaster  
Articulating Hitch, either  
D035 for 3.5t or less  
rated models, or  
D045 for models  
rated over 4.5t



### inverter

3000w Inverter Charger

## why choose the XC1 range?

Choose the XC1 Range for effortless off-grid escapes—light to tow, simple to set up, and powerful enough to keep you comfortable wherever the weekend takes you.

**where we're going we don't need roads.**

# XC1 specs



**XC1**

## resources

Solar	860w - Suman eArc 430w
Batteries	400a / 12v - Baintech IP67
Inverter	3kw Inverter
Victron Battery Management	5" Cerbo Screen, Victron Victron Mppt, 100/50 30a DC-DC Charger 120a Charger Resetable Fuses and a Spare provided for any non-resetable fuse
Diesel	5 Litres
Gas	2× 4.5kg bottles
Water	220 Litres of water *2× 110L tanks
Grey Water	40 Litre Portable Tank

## sleeping

- Innerspring Mattress
- 12v Fans (2x at Master Bed, 1x Bunk Bed)
- 240v Points
- 12v Cigarette & 12v USB-A & USB-C

## cooking

	Pull out bins Thetford Cooktop with Minigrill with either Pot Drawer or Oven (customer choice) Thetford Fridge / Freezer
Microwave	Plateless microwave

## living

Entry Door	Aussie Traveller Door with Gas Vent at Bottom, Separate Locable Screen Door & Pull Down Blind 240v Points with USB-A & USB-C x2
TV	24" Engalon TV with wall bracket and mount
Cooling	(& Electric Heating) Roofmounted Houghton 2800w inverter aircon/heater
Heating	AU Focus Diesel Heater
Stereo	1x UE Boom Portable Bluetooth speaker
Interior Lighting	LED strip lighting above and below cabinetry 240v Points with USB-A & USB-C x1

## washing

Hot Water	Swift 28 Litre Gas / Electric Hot water
	240v Points with USB-A & USB-C
Washing Machine	Standard for couples models Optional for family models

## outdoor living

External Shower Entry	Flush mounted hot & cold with hose Standard Entry Handle
Exterior	12v Cigarette, USB-A & USB-C points
Entertaining	240v Outlet, and TV Mount on Awning Side Manual Awning with Ability to add Privacy Screen Picnic Table Gas Bayonette under Front awning side
Exterior Lighting	12v White / Amber Lighting Under Awning
Rear Bar	Standard rear bar with single spare wheel 2× 20L Jerry Can Holders
ToolBox	Large Dual Slide Toolbox
Exterior Styling	Kokoda Branded Capping

## towing

- Breakaway System
- Teko Independent Coil Spring Suspension
- 16" Alloy Wheels with Mud Terrain Tyres and Single Spare
- Cruisemaster Articulating Hitch, either D035 for 3.5t or less rated models, or D045 for models rated over 4.5t
- Tyre Repair Kit
- Bluetooth Reverse Camera and Screen
- Breakaway
- Manual Jockey Wheel
- Manual Stabiliser Legs
- Jack

## construction

- Galvanised steel chassis, painted black
- Black Side Protection to lower section of van (front, sides and rear)
- XPS bonded sandwich panel (roof, walls & floor)
- Cabinet Material - ABS Lightweight Ply

## who its built for.

The XC1 Range is built for travellers who want to dive into off-grid adventure—perfect for couples or families seeking rugged tracks, hidden coastlines, and scenic routes while staying comfortable and independent.

**your escape starts here.**

Customer  
Signature





# Couples C220

## specs

### Internal Fridge

274 Litre Thetford Fridge / Freezer

### Washing Machine

The C220 has a 3.2kg front load washing machine. The washing machine is tucked away, with access to it from outside.

### Number of Axles

Dual axle

### Flat Floor or Wheel Boxes

Flat floor

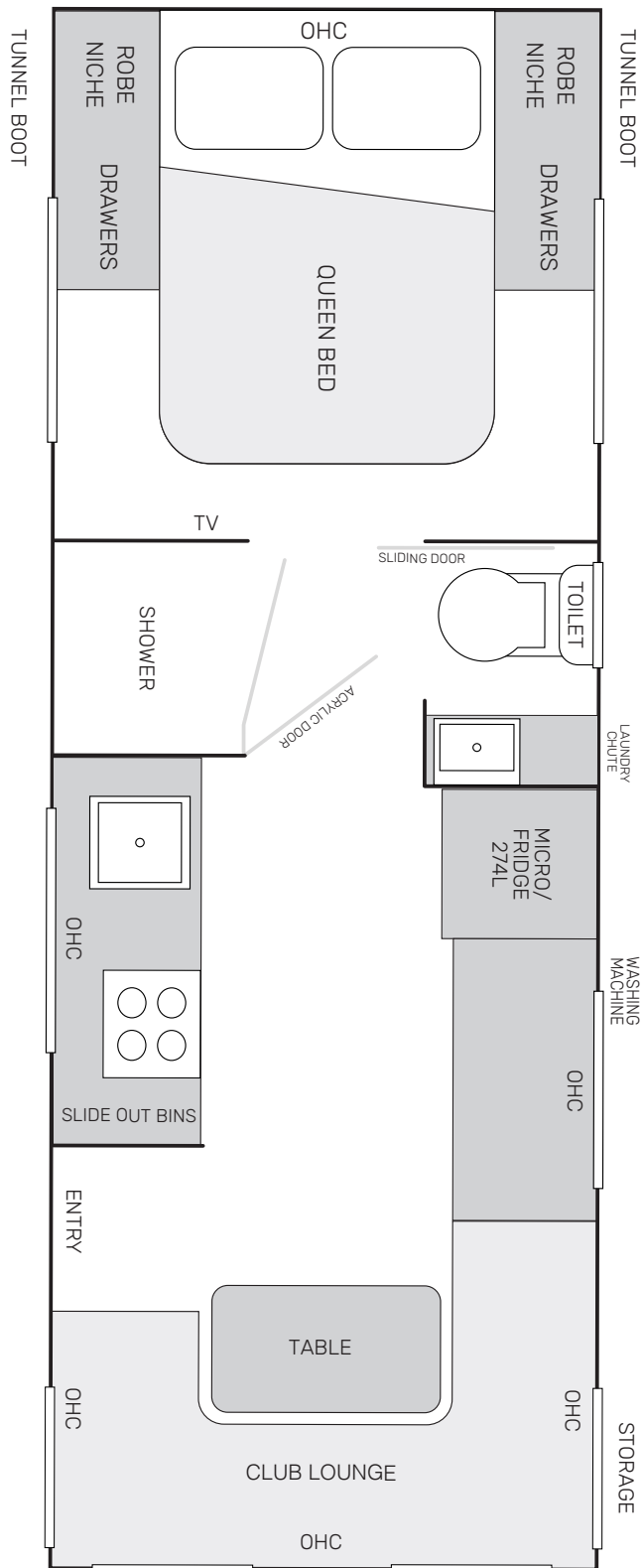

## why choose the C220?

A top choice for those planning a full-time travel lifestyle, offering room to live, work, and relax comfortably on the road.

comfort in every layout.

---

# FIAMMA CARRY BIKE A-FRAME MOUNT 2 BIKES



A compact and lightweight carry bike rack that fits on your caravan's A-Frame.

[CLICK HERE TO VIEW VIDEO](#)

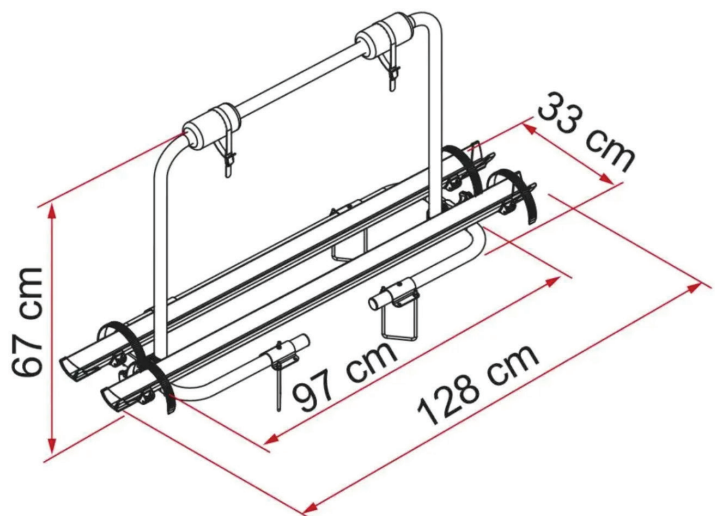
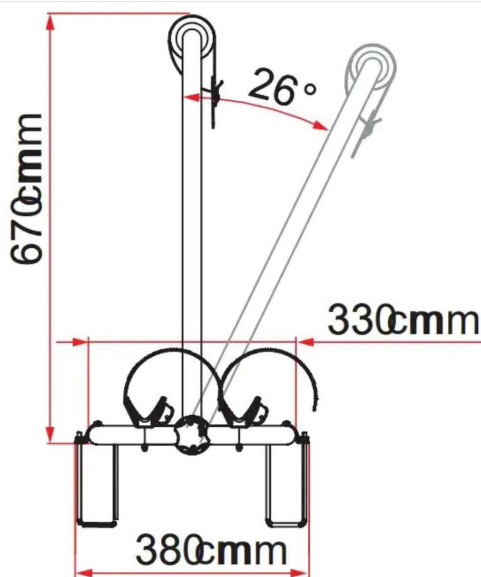

---

# FIAMMA CARRY BIKE A-FRAME MOUNT 2 BIKES



A compact and lightweight carry bike rack that fits on your caravan's A-Frame.

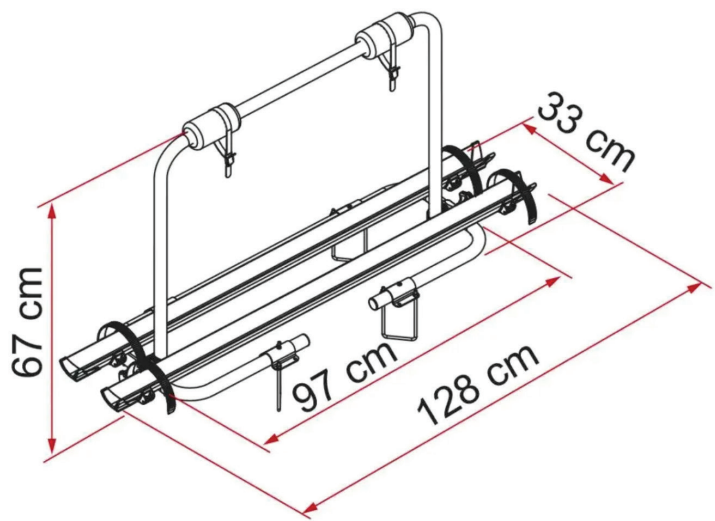
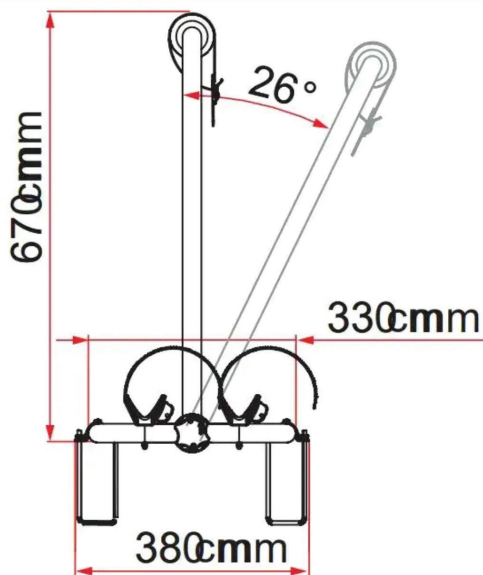

# Gibb River

*premium*



<b>Tapware</b>	Gun Metal Grey
<b>Accessories</b>	Gun Metal Grey
<b>Handles</b>	Gun Metal Grey
<b>Kitchen Sink</b>	Gun Metal Grey
<b>Ensuite</b>	White Basin
<b>Benchtops</b>	NX Laminate Doonagore Burren Rock PSC3627T

<b>Cupboards TOP</b>	Lana Grey Matt LX633
<b>Cupboards BOTTOM</b>	Charcoal Matt NX631
<b>Headboard and Magazine Pockets</b>	Warwick Eastwood collection Dove
<b>Lounge/Bunk Side Panels</b>	Warwick Eastwood collection Dove
<b>Floor</b>	Belgique Sand OAK

## colours that feel like home

Gibb River is inspired by the raw beauty of the Kimberley – bold, grounded, and built for the long way around. Sand Oak-look flooring brings warmth and durability underfoot, while Lana Grey uppers and Charcoal lower cabinetry create a strong, layered contrast that feels both modern and capable. Doonagore Burren Rock benchtops add a stone-inspired texture, perfectly matched with upgraded gunmetal grey hardware for a confident, premium finish. Finished with Warwick Eastwood Dove upholstery, Gibb River delivers an interior designed for real off-grid adventures.

**your style, your way.**

Kokoda Caravans  
1600 Sydney Rd  
Campbellfield VIC 3061  
Australia  
ABN: 61 632 386 997

## Quotation # S01620

**Your Reference**  
KC26126 - CC20 XC1

**Quotation Date**  
24/03/2026

**Salesperson**  
Mike

DESCRIPTION	QUANTITY	UNIT PRICE	TAXES	AMOUNT
C220 - XC1   22'1   \$149,000	1.00 Units	149,000.00	GST Inclusive Sales	\$ 149,000.00
2026 / C220-RD-QB-CL	1.00 Units	0.00	GST Inclusive Sales	\$ 0.00
XC1 Upgrade to Airbags with Go Air control system (Horizon leveling)	1.00 Units	6,800.00	GST Inclusive Sales	\$ 6,800.00
Install Fiamma Double Bike Carrier Mounted to Front	1.00 Units	1,550.00	GST Inclusive Sales	\$ 1,550.00
XC1 Upgrade to XC2 Battery Management Specification - 600ah batteries and extra panel to total 1290W solar)	1.00 Units	4,200.00	GST Inclusive Sales	\$ 4,200.00
External XG1- XG2 - Colour Scheme 2026 (All) - Cannot be selected for final sign-off	1.00 Units	0.00	GST Inclusive Sales	\$ 0.00



Kokoda Caravans Pty Ltd  
1600 Sydney Rd  
Campbellfield VIC 3061  
ABN:61 632 386 997

2026 INTERNAL COLOURS - GIBB RIVER premium	1.00 Units	2,500.00	GST Inclusive Sales	\$ 2,500.00
SUBTOTAL (EX. GST)				\$ 149,136.37
GST 10%				\$ 14,913.63
<b>Total</b>				<b>\$ 164,050.00</b>

**Banking Details:**

Unify Partners Pty Ltd  
BSB: 063492  
Account:10355215



stronger, lighter & built for off-road conditions

## Kokoda's Frameless Bonded Sandwich Panel Construction

When choosing a caravan built for off-road and corrugated roads, construction quality matters.

That's why Kokoda Caravans use advanced frameless bonded construction, replacing outdated screw-fix methods with high-strength chemical bonding that delivers exceptional durability, stability, and long-term reliability.

Unlike traditional mechanically fixed caravans, which rely on screws that loosen over time, our frameless sandwich panel design is bonded together as a single, high-strength structure, ensuring a rattle-free, low-maintenance caravan designed for tough Australian conditions.



### Why Is bonded construction better than screws?

#### 1. How Does Bonded Construction Improve Caravan Strength?

Our frameless bonding process chemically fuses the walls, roof and floor into one seamless structure, eliminating weak points caused by screws and rivets that shift and loosen over time.

This results in a caravan that's stronger, more rigid and better at absorbing shocks from rough terrain.

#### 2. What Makes It Ideal for Off-Road and Corrugated Roads?

- Vibration resistance – Bonded construction absorbs impacts, reducing internal movement and preventing fittings from coming loose.
- Less maintenance – No screws to tighten or check after rough road travel.
- Superior structural integrity – Ensures cabinets, walls and joins stay firmly in place, preventing internal damage.

#### 3. Is Bonded Construction More Reliable Than Screws?

Yes. Traditional caravans use hundreds of screws and rivets, which can:

- Loosen over time, leading to squeaks, rattles and panel separation.
- Cause leaks or dust ingress as gaps widen with movement.
- Require ongoing maintenance, tightening screws after long trips.

With Kokoda's bonded structure, none of these are an issue—giving you a caravan that's engineered to last with minimal upkeep.

#### 4. Does Bonding Improve Insulation and Weatherproofing?

Absolutely. Our frameless sandwich panel design creates a fully sealed, dust-resistant and highly insulated structure. This means:

- Loosen over time, leading to squeaks, rattles and panel separation.
- Cause leaks or dust ingress as gaps widen with movement.
- Require ongoing maintenance, tightening screws after long trips.

## seamless strength that lasts

Bonded construction creates a seamless, rock-solid body that's stronger, lighter, and built to handle the roughest Australian tracks. By bonding panels instead of using screws, we eliminate weak points where water or dust can sneak in, giving you a caravan that stays rigid, weather-tight, and adventure-ready for years to come.

**bonded for unmatched durability.**



## sandwich panel vs. meranti frame vs. aluminium frame. which is best?

Choosing the right caravan construction method is critical for durability, strength, weight, and long-term reliability. Here's how Kokoda's frameless bonded sandwich panel construction compares to traditional Meranti timber frame and Aluminium frame caravans.

FEATURE	FRAMELESS BONDED SANDWICH PANEL	ALUMINIUM FRAME	MERANTI TIMBER FRAME
Strength & Durability	✓ High-strength bonding eliminates weak points, absorbs vibrations	✓ Stronger than timber but still relies on rivets & screws that can loosen	✗ Timber frames weaken over time, especially in off-road conditions
Off-Road Performance	✓ Built to handle corrugated roads with no movement or screw failure	✓ Lightweight, but riveted joints can work loose over time	✗ Timber can flex, leading to cracking & structural issues
Weight	✓ Lightweight composite panels improve towing efficiency	✗ Heavier than bonded sandwich panels	✗ Heavier due to timber frame & cladding layers
Weatherproofing & Insulation	✓ Fully sealed structure for superior insulation & dust-proofing	✓ Resistant to moisture, but not as well-sealed as bonded panels	✗ Susceptible to water damage & leaks over time
Maintenance Needs	✓ Low—no screws to tighten, no gaps to seal	✗ Aluminium screws & rivets can loosen, requiring regular maintenance	✗ Requires ongoing maintenance for frame integrity & sealing
Longevity	✓ Designed to last decades with minimal upkeep	✓ Lasts longer than timber, but requires ongoing frame inspections	✗ Timber weakens over time, reducing longevity

## why frameless bonded sandwich panels are superior.

- Zero timber – No risk of rot, water damage, or warping.
- No screws or rivets – Eliminates weak points that loosen over time.
- Stronger than aluminium – Bonded panels distribute weight evenly, reducing stress points.
- Best for off-road & full-time travel – Withstands corrugations, impacts, and extreme climates.

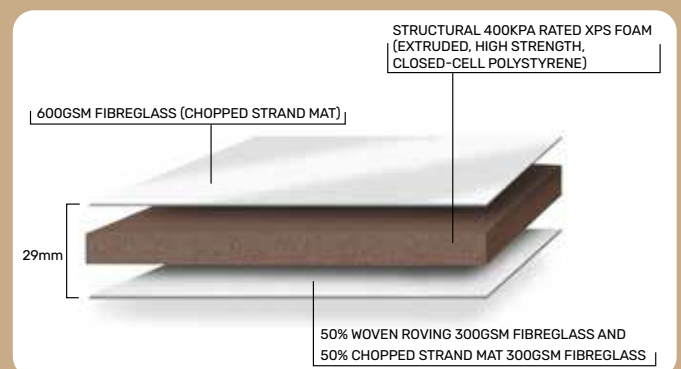

**stronger, lighter, adventure-ready.**



## bonded construction vs. traditional screw-fixed caravans

FEATURE	KOKODA BONDED CONSTRUCTION	TRADITIONAL SCREW-FIXED
Overall Strength	High-strength bonding creates a rigid, durable structure	Screws and rivets loosen, causing movement & instability
Off-Road Durability	Absorbs shocks & vibrations, reducing internal wear	Screws shake loose, requiring maintenance after rough travel
Maintenance Needs	Minimal—no screws to tighten, less wear over time	Requires frequent tightening & repairs
Insulation & Sealing	Seamless construction for better insulation & dust protection	Screwed panels create gaps for heat, dust, and water ingress
Longevity	Designed to last longer with fewer structural issues	More prone to wear, squeaks, and ongoing maintenance



## faq's about caravan construction

### What is the best caravan construction method for off-road travel?

Frameless bonded sandwich panels are the best choice for off-road caravans, offering superior strength, reduced maintenance, and better insulation than both timber and aluminium frame caravans.

### What are the downsides of timber-framed caravans?

- Timber frames are prone to water damage, rot, and warping.
- Heavier than modern materials, increasing towing weight.
- Weaker in off-road conditions, with frame flexing leading to structural issues.

### If something happens to my caravan panels, how easy are they to repair?

Repairs are simple—any qualified caravan repairer can fix the panels using standard methods, with no need for specialist equipment.

### Is aluminium or bonded construction better?

Bonded sandwich panel construction is lighter, stronger, and requires less maintenance than aluminium-framed caravans, which still use screws and rivets that can loosen over time.

### Does bonded construction make a caravan lighter?

Yes! Kokoda's frameless bonded panels are lighter than traditional builds, making towing easier and reducing fuel consumption.



## final thoughts: why this construction method matters

With Kokoda's frameless bonded construction, you're investing in a stronger, lighter, and more reliable caravan that's built to handle Australia's toughest roads - without the maintenance headaches of traditional builds. If you're looking for a caravan that can go further, last longer, and provide better comfort, Kokoda's bonded sandwich panel technology is the clear choice.

**the power of seamless construction.**

# upgraded, updated & unapologetically better.

## traditional

## Kokoda way

### stereo



- Prone to electrical connection issues, speaker failures
- Reception and bluetooth connect issues
- Blaring music from the van only

### portable bluetooth speaker



- Portable to your location
- Easy bluetooth connection to your phone
- Long Battery life
- Able to pair multiple speakers together

### antenna



- Prone to electrical connection issue
- Continual reception issues
- Aerial project shade over roof solar system
- Roof penetration water leaks

### starlink mini



- Reliable efficient internet service
- Dedicated 12V socket located outside of the van
- Smart TV provided that works seamlessly

### solar / skylights



- Valuable roof space taken up where solar could be used
- Can only use traditional solar panel max 200w each
- Tradition solar panels must be fixed to roof (leak issues)

### solar / no skylights



- Maximum roof space available
- Space allows for Sunman eArc 430 panels (High Quality & Super Efficient)
- Solar Panel space up and bonded to the roof (No Fasteners) - No potential leaks

### grey water tank

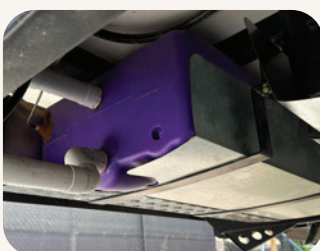

- Limits time at locations
- Maximum 110L
- Use valuable spot that could be fresh water tank
- Stores water for longer, potential black water

### portable grey water tank



- 40L capacity that can be emptied on day trips allowing for longer stays
- Easy to use
- Maximise total fresh water capability of caravan

the Kokoda you love — now evolved.

Australian made & owned.



## the price family

Kokoda Caravans is proudly Australian-made, owned and operated by the Price Family, who bring decades of experience in local Australian manufacturing and a lifelong passion for off-road travel.

Before taking ownership of Kokoda in 2019, they operated Rowville Horse Trailers, a premium brand known for quality and innovation. They pioneered the Equivan - the first horse float and caravan hybrid - showcasing their ability to blend durability with comfort.

This expertise ensures every Kokoda Caravan is built to withstand Australia's toughest conditions while providing home-like experience.



### a family legacy

At the heart of it all is the Price family, whose unwavering commitment to quality, innovation, and customer experience has propelled Kokoda to the forefront of the caravan industry.

For the Price family, Kokoda is more than a business; it's a mission to redefine off-grid adventure.

Their philosophy is simple: Build for Real Adventurers. As passionate travellers themselves, they design every van with firsthand experience and no compromises.

### meet the owner Trevor Price

Trevor Price, at the helm of Kokoda, brings a fierce dedication to pushing the boundaries of what's possible in off-road and off-grid caravanning.

His leadership has driven Kokoda to consistently innovate, ensuring that every model delivers the perfect balance of rugged strength and refined luxury. With a background in business, engineering and an unshakable entrepreneurial mindset, Trevor has ensured that Kokoda remains ahead of the curve, not just meeting customer expectations, but redefining them.

## strength, passion & pride

Built with strength, crafted with passion, and delivered with pride—every Kokoda Caravan is designed to take you further, handle every adventure with confidence, and make life on the road effortlessly comfortable.

crafted with care, driven by family values

Australian made & owned.



BUILD  
WITH  
STRENGTH

CREATE  
WITH  
PASSION

WITH  
PRIDE



our factory

# built with quality, in Melbourne

Kokoda proudly designs and manufactures luxury off-grid caravans, all in-house, right here in Campbellfield, Victoria. Our Australian factory is the beating heart of our operation, where you can trust that every caravan is crafted to handle Australia's toughest conditions. Initially outsourcing production in 2011, manufacturing was brought in-house to ensure the highest standards of innovation and quality. Today, our state-of-the-art, fully-owned factory integrates cutting-edge technology, including 3D CAD designs, CNC machinery and 3D printing, enabling precision at every stage.



## manufacturing a hands-on approach

Every Kokoda Caravan is built in-house. Our expert team oversee the entire process, guaranteeing your van meets the highest industry standards before it leaves our factory.

Our expert team includes:

- Local chassis specialists – Ensuring a rock-solid foundation for durability and off-road performance.
- Electrical and plumbing professionals – Seamlessly integrating wiring, appliances and plumbing for a seamless experience.
- Carpentry and interior fit-out teams – Creating modern and functional living spaces.
- Quality control specialists – Rigorously checking each caravan before delivery to our customers.



## factory direct servicing and repairs

The service and support you receive after purchase is just as important as the build itself.

Our Melbourne factory provides direct servicing, maintenance and repairs, handled by the same experts who built your van.

We also have a trusted network of approved service providers across Australia, ensuring expert support wherever your travels take you.

## a customer first-approach, every step of the way.

Buying a caravan is a big decision, and we're here to support you before, during, and after your purchase. Whether you have questions, need servicing, or just want some travel tips, our team is always here to help. We're committed to making your Kokoda experience second to none.

built locally, trusted nationally.

Australian made & owned.



# keeping you on the road

Your caravan should be the least of your worries. That's why we back every Kokoda Caravan with a 3-year warranty and nationwide servicing support, so you can focus on making memories, not maintenance.

Whether it's routine servicing, troubleshooting or repairs, our team is here to help you keep exploring Australia with confidence.



## dedicated support team

- Proudly Australian-Made – Designed and manufactured in Melbourne, built for Australian conditions.
- Nationwide 3-Year Warranty – Providing peace of mind wherever your travels take you.
- Dedicated Support Team – Our experts are always available to assist with servicing, maintenance, and repairs.
- With decades of experience serving customers across Australia, we understand what it takes to provide a best-in-class ownership experience.
- We strive to go above and beyond, ensuring your caravan ownership is as easy and stress-free as possible.

## service that protects your investment.

Your Kokoda will remain road-ready with a minor service at 3 months and a major service every 12 months. Regular servicing keeps your caravan performing at it's best, ensuring safe and worry-free travel for years to come.

- Servicing Options - Kokoda Caravans can conduct your services, or you can use one of our approved service partners nationwide
- Approved Service Partners - If servicing away from a Kokoda-approved provider, you should contact us before servicing to ensure they meet our high standards
- Service Checklist - We provide a detailed checklist to guarantee all key components are inspected, ensuring your van remains in top shape
- Regular maintenance means worry-free travel, letting you focus on the adventure ahead.

## nationwide repair network

Even the best caravans need attention from time to time. If you need repairs, our nationwide network of trusted repairers will get you back on the road quickly, so the adventure never stops. With years of experience working on Kokoda Caravans, they'll get you back on your journey as quickly as possible. Need help finding a repairer? Get in touch with us, and we'll connect you with the right expert.

**backed by warranty, built for peace of mind.**

Australian made & owned.



## why choose Kokoda

A Kokoda Caravan is more than just a purchase, it's an investment in your lifestyle and future adventures. That's why we build caravans that are not only durable, functional and stylish but also backed by expert craftsmanship and a customer-first approach.

If you're searching for the best family caravans in Australia or the toughest caravans for off-road travel, Kokoda delivers. Our caravans are built to handle extreme conditions with reinforced chassis, premium suspension, and high-end interiors, giving you durability and comfort wherever the road takes you.



Here's why thousands of Australians choose Kokoda

**Australian owned & built for tough conditions.**

Unlike imports, Kokoda Caravans are designed and manufactured in Australia to handle extreme weather, rugged roads and long travel distances. Whether tackling the Outback, winding through the High Country or cruising the coast, our vans are built for strength and reliability.

**adventure ready.**

Every Kokoda Caravan features a reinforced chassis, premium suspension and high-quality off-road components, ensuring you can explore remote destinations with confidence, without sacrificing comfort.

**customer-first support every step of the way.**

From your first enquiry to long-term after-sales support, Kokoda is with you for the journey. Our expert team helps you choose the right van, and our network of approved service providers across Australia ensures you're covered wherever you roam.

**premium quality great value.**

Kokoda delivers high-end materials, modern finishes and top-tier appliances without the excessive markups. Our focus is on quality that lasts, giving you the best value for your investment.



## join the Kokodian community

When you buy a Kokoda, you're joining a community of passionate off-road explorers who trust Kokoda off-grid caravans for their adventures. Swap travel tips, share experiences, and explore knowing you have a support network on and off the road.

**engineered for the long road, trusted by travellers.**